



- Multi Waste Shredding

- Tyre Shredding

- Paper Shredding

# EV110E

## PERFORMANCE CHARACTERISTICS:

- 60 Kw/ 80 Hp Maximum Power
- 22—24 Rpm Cutter Speed Rotation
- 25, 50 or 75 mm Shred Width
- 1100/ 1400 mm x 600 mm Cutting Chamber Opening
- 21.4 m/min Cutting Speed
- 4000 Kg per hour\*
- 6000 Kg per hour\*\*
- 78 DbA @ 1 meter (no load)
- Recommended In-feed: Conveyor Belt
- Recommended Out-feed: Conveyor Belt
- Electronic Controls
- Stationary and Mobile Applications



\* Normal Office Paper Under Ideal Conditions

\*\* Normal Collection of Passenger and Truck Tyres Under Ideal Conditions

Specifications are subject to change without notice. Contact your nearest distributor/ agent for up-to-date specifications prior to purchase.

# EV110E

## TECHNICAL SPECIFICATIONS:

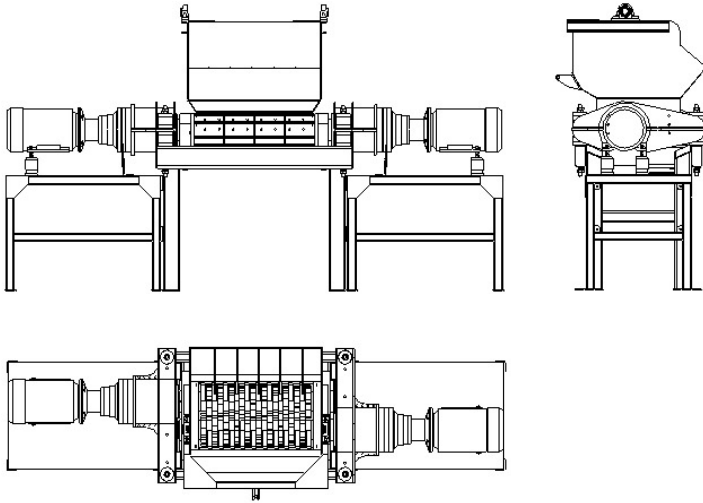

### PHYSICAL DIMENSIONS:

Total Height:	2520 mm
Total Length:	4570 mm
Total Width:	1220 mm
Ground Clearance (underneath shredder):	1120 mm
Ground to Hopper Entrance Lip Height:	2190 mm
Hopper Opening:	1200 x 1220 mm
Shredder Chamber Opening:	1100/ 1400 x 600 mm

<b>SHREDDER NAME:</b>	<b>EV110E (Electric)</b>
Number of Motors	2 x 30Kw
Number of Gearboxes	2
Type of Gearboxes	Planetary Reduction
Cutter Width	25mm, 50mm or 75mm
No. of Hooks per cutter	5
Cutter Diameter	310mm
Distance between Shafts	240mm
Hex Shaft Diameter	140mm AF
Critical Shaft Length	1100mm (Tyres), 1400mm (Municipal)
Cutter Chamber Opening	1100mm/ 1400mm x 600mm
Cutting Chamber Height	470mm
Hopper Height	780mm
Stand Height	1270mm
Total Height	2520mm
Floor Footprint Dimensions	4570mm x 1220mm
Weight	3200 Kg
Capacity/ Throughput Rate	4000 kg per hour*/ 6000 kg per hour**
Cutting Tip Force	14800 Kg/ 32560 lbs per meter of shaft length

\* Normal Office Paper Under Ideal Conditions

\*\* Normal Collection of Passenger and Truck Tyres Under Ideal Conditions

Specifications are subject to change without notice. Contact your nearest distributor/ agent for up-to-date specifications prior to purchase.